

Turning a segmented Beads of Courage vessel “Kit” Instructions for a plain vessel.

For those who choose to build from a kit.

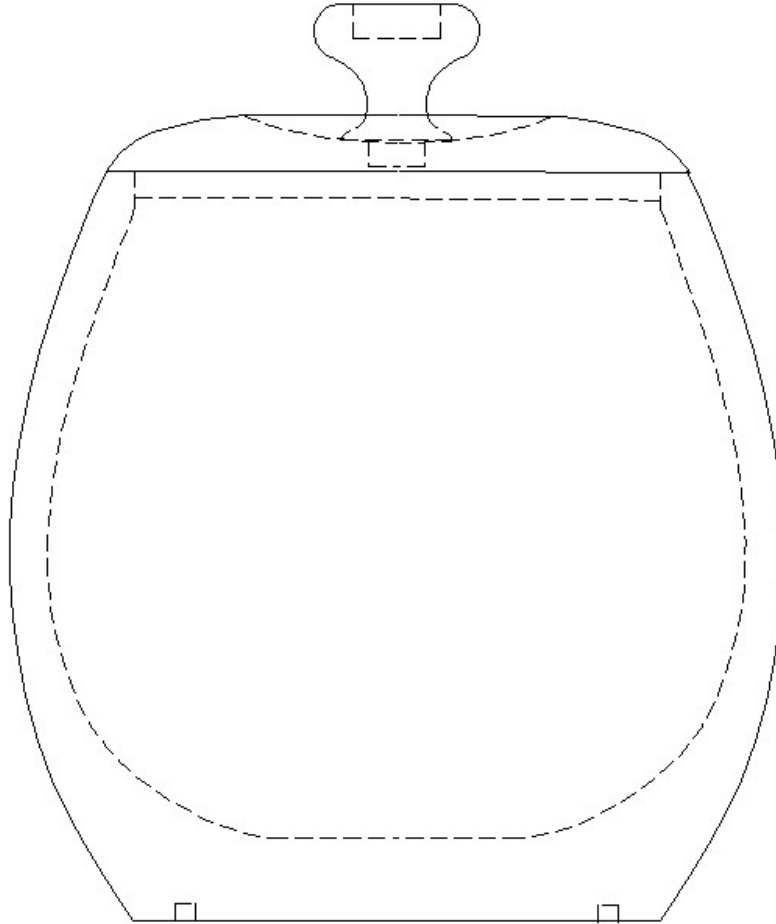

These instructions are intended to enable Inland Woodturners members to successfully complete a segmented vessel suitable for donation to Beads of Courage from a kit.

I have written these instructions based on how I turned mine. If you have a better way feel free to use it.

This a great opportunity for club members to use their skills to help children with long term illnesses.

The kit

The kit provided by the club contains almost everything you will need to complete the vessel.

10 rings, glued up and sanded flat.

4" OD O-Ring

Beads of Courage bead

Complete instructions

Gluing the rings together and turning the vessel

1. The hardest part of gluing the rings together is getting them aligned in two axis at the same time. All the rings must be concentric, if a ring get far enough out of alignment you won't have enough material to turn the desired contour. You also must maintain the radial alignment so the joints between the segments looks like a block wall. Meaning that the joint between two segments must line up with the center of the segment above and below it in the finished vessel. The illustration below will show both the concentric and radial alignment of rings.

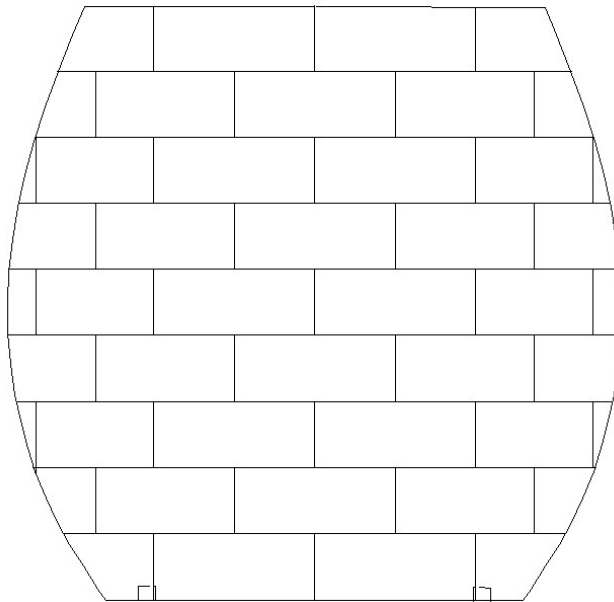

2. Gluing the rings together is best done on the lathe. The following steps will show you one way to do it. It is certainly not the only way or even the best way but if you don't have a better way, give it a try.

You will need:

Standard 4 jaw chuck

3 sacrificial squares (2 1/2" square)

Shop made Ring Alignment Jig

3. Before you start to glue up rings it is important to note that you usually don't glue up everything and then start to turn it. It is actually a combination of gluing up several rings, turning those and then gluing more rings until you have all rings glued and turned.

4. For this vessel you will start with the lid (ring 10).

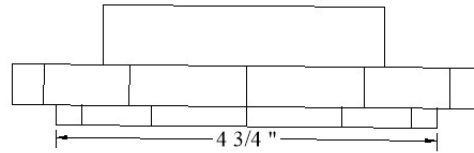

5. Start with a 2 1/2" square sacrificial. You will attach ring 10 to the sacrificial with double sided tape (Carpet tape). Align the corners of the sacrificial with the joints of every third segment. See the drawing to the right. Once the sacrificial is secured to ring 10 place the assembly in a 4 jaw chuck.

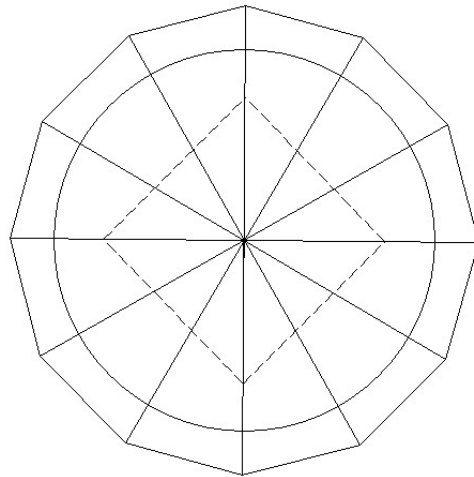

6. Turn a tenon on the bottom of the ring to a diameter of 4 3/4" and 1/4" deep. Because this is for a sick child we will take a few extra precautions to protect them from sharp edges. On the edge of the tenon you just cut, roll a 1/16" radius fillet to soften the edge. Because of the way the lid is held in the chuck jaws this is all you can turn now. This gives you the ability to get a perfect fit between the lid and vessel later.

7. Next, attach another 2 1/2" square sacrificial to ring 1 in the same way you did for ring 10. Place the assembly in a 4 jaw chuck and cut the groove for the o ring. The O.D. of the o ring is 4" and the cross section is 3/16" so your groove will be 3/16" wide. The width of the groove is critical. "Sneak up" on the final width so you have a snug fit. If the fit is too loose there will not be enough friction to hold the o ring in the groove.

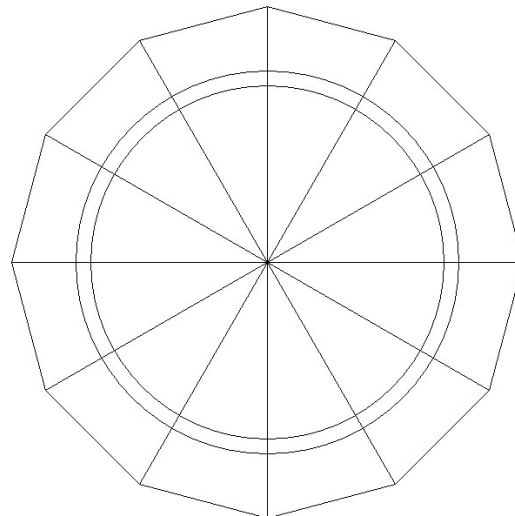

8. Next, you will glue a 2 1/2" sacrificial to the bottom of ring 1.

Position the sacrificial in the same way you did the other two. Bring up the tailstock with no attachment to apply pressure while the glue dries. Reverse the ring in the chuck and remove the first sacrificial (you will use this square later). Remove ring 1 from the chuck.

9. Now is a good time to fabricate the Ring Alignment Jig. Start with a piece of scrap material (MDF works well) larger than 7 5/8" square. Glue a 2 1/2" square sacrificial to the center of the piece. Mark the center of the sacrificial, you will need that later. Scribe a 7 5/8" circle using the center of the sacrificial and cut that circle on a band saw staying well outside the line. Attach the sacrificial to a 4 jaw chuck and turn the scrap piece to a diameter of 7 5/8". Cut out the Ring Alignment Jig found at the back of these instructions and glue it to the scrap piece. Remove the jig from the chuck.

10. Now you are ready to start assembling the vessel. Attach ring 1 to the chuck. Find the polygon on the ring alignment jig for ring 2. Align ring 2 with that polygon and attach it using a small piece of double sided tape. Apply glue the rings and press them together. Bring up the tailstock with a live center. Align the live center with the center of the sacrificial and apply just enough pressure to hold them together. This will give you concentric alignment, now you rotate ring 2 until you have radial alignment. Once you are sure you have proper alignment apply more pressure with the tailstock until the glue has tacked up (about 30 min.).

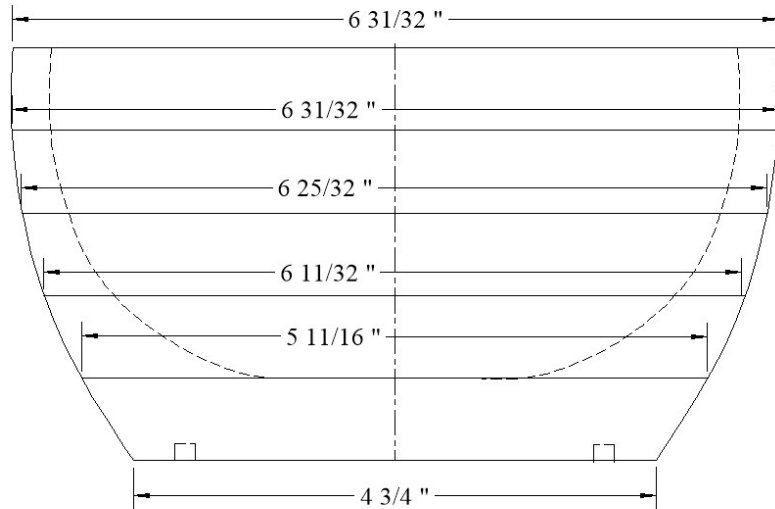

11. Remove the jig from ring 2 and apply ring 3 to it. Glue up ring 3 in the same way you did ring 2. Repeat these steps until you have five rings glued up. Allow them to dry overnight and you are ready to start turning the vessel. The illustration to the right shows all the dimensions you will need to turn this portion to the correct shape.

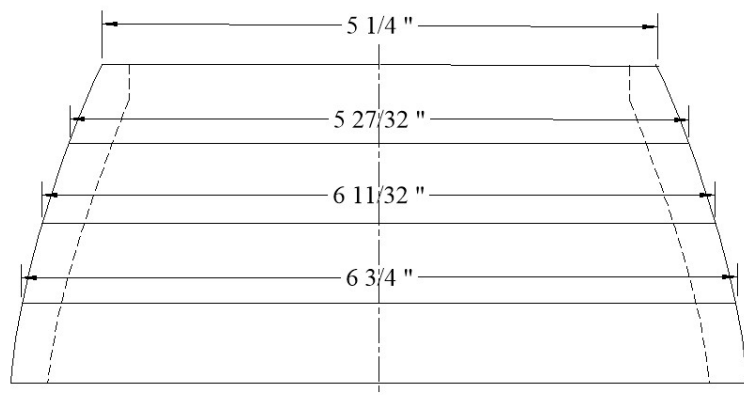

12. Following the same steps as before, glue the other 4 rings to the vessel and turn the outside to the dimensions show here.

13. A dimension is not shown for the inside of ring 9. This is where you will use the lid you have already turned to carefully fit the lid to the vessel. You do not want a snug fit, but at the same time you don't want a loose fit either.

14. Once you have the correct fit for the lid, roll a $1/16$ " radius fillet to soften the edge. Now turn the rest of the inside of the vessel and sand smooth. If you are going to finish the inside on the lathe now is a good time to do it. I use beeswax to finish the inside of mine.

15. Once you have finished the inside return the lid to the vessel and bring up a live center to hold it in place and turn the rim of the lid to match the contour of the vessel. You will also roll a fillet on the lid and outside of the vessel to soften the edge.

16. Now you need to turn the depression in the top of the lid and drill the hole for the handle. To do this use duct tape or other very strong cloth base tape and tape the lid to the vessel. Remove the live center and slowly and carefully turn the depression and drill a $1/2$ " hole $1/4$ " deep.

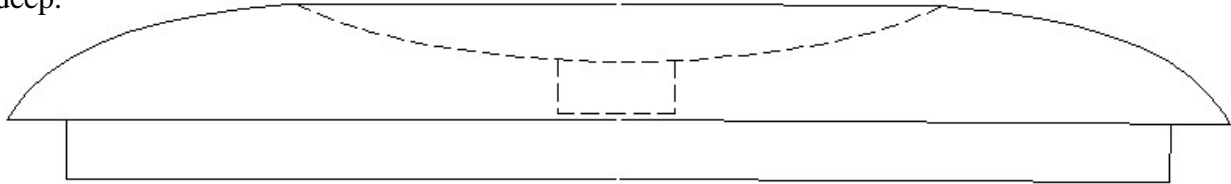

17. Remove the tape and bring up the live center again and sand the entire vessel and lid. If you are going to finish the outside of the vessel on the lathe do that now.

18. Part off the sacrificial from the bottom of the vessel and sand and finish the bottom.

19. Turn the handle according to the drawing. You probably don't have a $25/32$ " drill bit so use a $3/4$ " and enlarge it with a parting tool. The bead you will glue into this hole is not completely round and your fit will not be perfect. Just slowly enlarge the hole until the bead will fit.

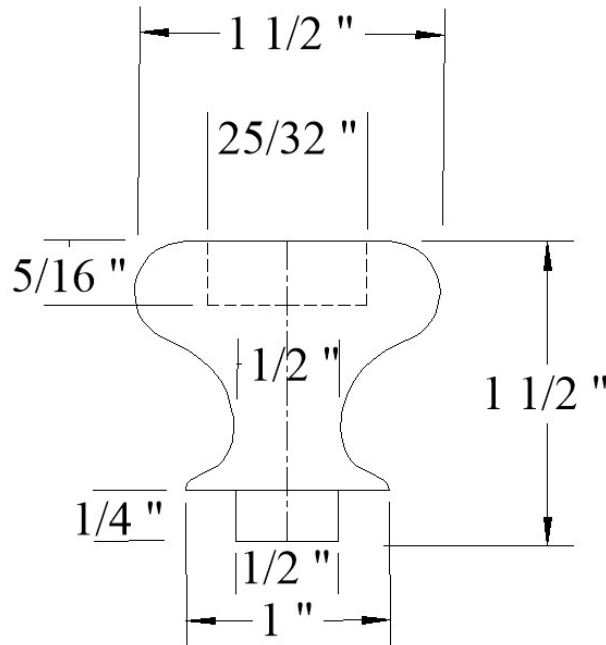

20. Finish the handle and glue the bead in place. Once it's dry, glue the handle to the finished lid.

I hope you have enjoyed turning you "Beads of Courage" vessel.

